

TOP VIEW

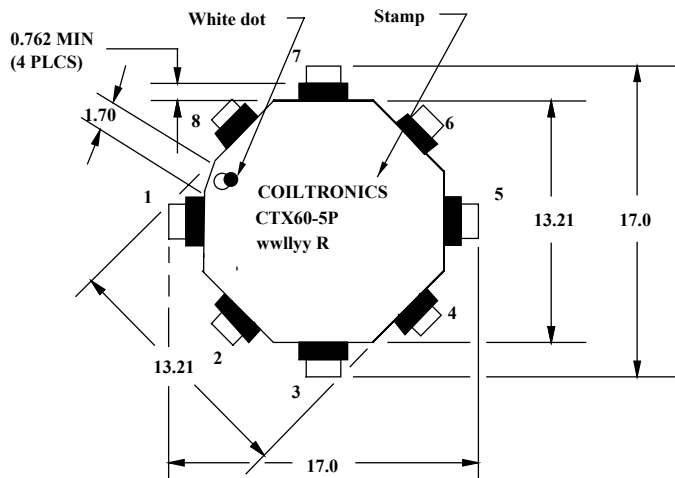

FRONT VIEW

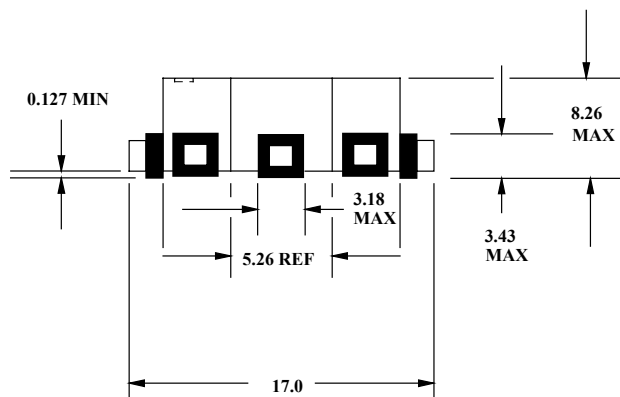

RECOMMENDED PCB PAD LAYOUT

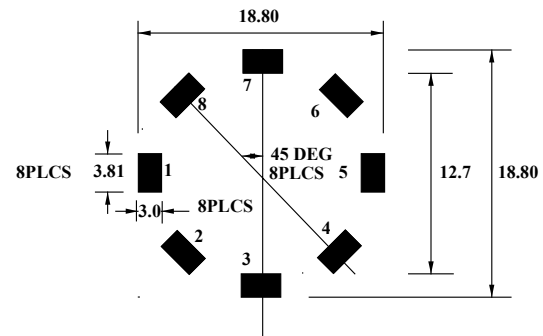

ELECTRICAL CHARACTERISTICS

- OCL @ 20 KHz, 0.100 Vrms, 0 Adc, (1,2,3,4 - 5,6,7,8): 51 - 69 uH
- OCL @ 20 KHz, 0.100 Vrms, 1.83 Adc, (1,2,3,4 - 5,6,7,8): 38 uH minimum
- DCR @ 20°C pins (1-8): 0.38 Ohms maximum
- DCR @ 20°C pins (2-7): 0.38 Ohms maximum
- DCR @ 20°C pins (3-6): 0.38 Ohms maximum
- DCR @ 20°C pins (4-5): 0.38 Ohms maximum
- Hipot @ 300Vdc between windings for 1 second
- Turns ratio (1-8) : (2-7) : (3-6) : (4-5) = 1.00 +/- 2%

SCHEMATIC

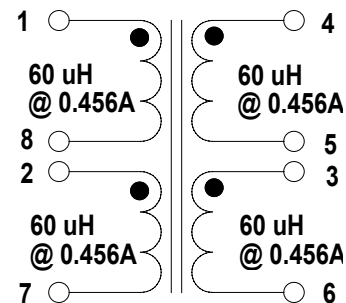

Notes:

- 1) All dimensions are in inches.
- 2) Tolerances are .XX +/- 0.5 mm, .XXX +/- 0.254 mm unless otherwise noted.
- 3) All soldering surfaces to be coplanar within 0.15 mm.
- 4) wwllly= Date Code, R= Revision Level
- 5). For 60 uH @ 1.83 Adc, tie pins (parallel) 1,2,3,4 (starts) and tie pins (parallel) 5,6,7,8 (finishes)
- 6). For 960 uH @ 0.456 Adc, series connect pins 2 to 8, 3 to 7, 4 to 6 and measure across (1-5)

COILTRONICS, INCORPORATED

6000 Park of Commerce Blvd, Boca Raton, FL 33487

Inductor Transformer

60/960 uH @ 1.83/0.456 Adc

SMT, Octa-pac™ style 5-295 case, 8 pad

SIZE Drawing Number: **CTX60-5P**

A Revision Level: B Sheet Number: 4